

## FONTANA COMMERCIAL AUTOMATIC BRUSHED NICKEL LIQUID FOAM SOAP DISPENSER SPECS

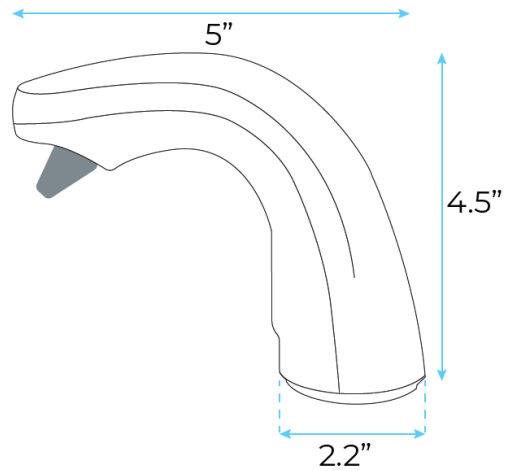

### **SPECS :**

Product Type: Commercial  
Main Construction Material: Brass  
Mount Type: Deck  
Handle Type: Infra-Red  
Input adapter: 110-240V DC 0.55A  
Output Adapter: 15V DC 1.6A Class 2  
Control box input: 15V DC 0.2A Class 2  
Valve/Cartridge Type: Solenoid Valve  
Plumbing System Requirements: Suitable for all plumbing systems  
Sensing Range: 5 - 15cm  
Activation Time: 0.5 - 1 secs  
Viscosity of Liquid Soap: 100-3500cp (mpA .s)  
Isolation Included: NO

